

## Stone Mountain BluSkye® Bluetooth® Speaker Microphone (SM) User Manual

BluSkye® is a feature rich, industrial grade Bluetooth® speaker microphone that supports Android, iOS, Windows and LMR platforms running Push To Talk (PTT) applications.

### Starting Out

1. Charge the SM for at least six (6) hours prior to first use. When the SM is powered off, there is no LED charging indication, though charging is still occurring. **Note: Be sure to only charge with Stone Mountain approved charging accessories.**

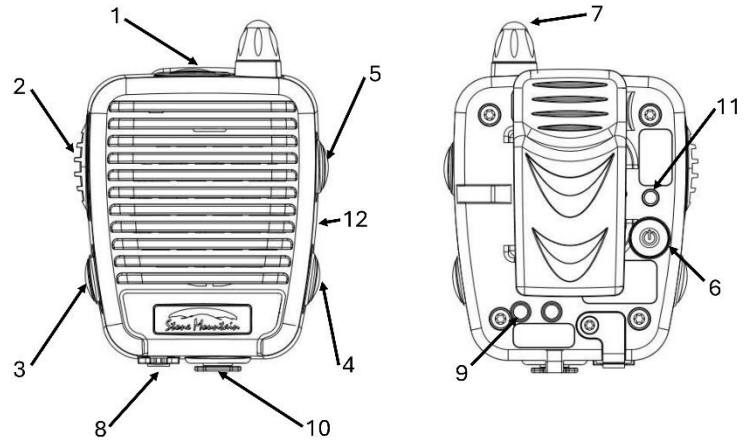

	Button	Primary Function	Button	Secondary Function	Notes
1	SW1	Emergency/programmable			Note 1
2	SW2	PTT			
3	SW3	<b>RampClik™</b> volume control			
4	SW4-P	Programmable button (e.g. message replay, etc.)	SW4-S	Channel down	Note 1 & 2
5	SW5-P	Phone call control	SW5-S	Channel up	Note 1 & 2
6	SW6	On/off, pairing, etc.			
7	SW7	<b>Tac10™</b> rotary channel select (optional)			
8		3.5mm Rx audio port			
9		<b>TruDock™</b> cradle contacts			
10		5.5mm charging port			
11		LED indicator			
12		<b>QuickPair™</b> NFC pairing location			Note 3

### Notes

1. Buttons may have different functions depending upon the PTT app. Refer to your PTT app and/or device user manual for further details.
2. To toggle between Primary (P) Function and Secondary (S) Function, press and hold SW3, then immediately press and hold SW4. An audible beep identifies which Function is active as follows:
  - **One beep:** Primary Function is active.
  - **Two beeps:** Secondary Function is active.
3. **QuickPair™** requires an Android device equipped with NFC. **QuickPair™** is not available for iOS.



## Operating the Speaker Microphone

**Power On:** Press and hold SW6 for three (3) seconds and release. An audible **booBEEP** means the unit is on.

- The LED flashes **red**: The SM *is not* connected/paired. Follow instructions for pairing below.
- The LED flashes **blue**: The SM *is* paired. **Wait 20 seconds after Power On prior to engaging in a duplex/ptt call, etc.**

**Power Off:** Press and hold SW6 for three (3) seconds and release. An audible **boop, boop, BEEboop** means the unit is powered off.

**QuickPair™ NFC Pairing (Android Only):** Ensure NFC is enabled on your device. With the microphone turned off, press and hold SW6 for six (6) seconds. An audible **booBEEP** followed by a **beeBEEP** means the unit is in pairing mode. The LED will flash **red & blue** while in pairing mode. Place the SW4 and SW5 flush/close to the NFC reader on your device. Select **“Pair”** when the message **“Pair with BluSkye BT?”** appears. Allow up to 10 seconds for the device to recognize the SM.

**Traditional Pairing:** With the microphone turned off, press and hold SW6 for six (6) seconds. An audible **booBEEP** followed by a **beeBEEP** means the unit is in pairing mode. The LED will flash **red & blue** while in pairing mode. Follow the instructions of the device/phone to connect and pair to the SM. Select **“BluSkye BT”**. Do not select **“BluSkye LE”**, as this is handled implicitly by the PTT app if necessary.

The SM will emit a **BEEP BEEP** tone and the LED will blink **blue** upon successful pairing. **Wait 20 seconds after pairing prior to engaging in a duplex/ptt call, etc.**

**Note:** During regular use, it is recommended to power cycle the SM once every 24 hours to ensure a stable Bluetooth connection.

**Checking Configuration:** The SM comes factory configured. To check the configuration, ensure the SM is powered on. Press and hold SW3, SW4 and SW5 for five (5) seconds. An audible **boop, boop** will be followed by a **booBEEP**. The LED will flash **pink**. Next will be some number of **BEEP**'s that correspond to the SM's present **Configuration Number**, e.g.:

- **1 BEEP/1 red LED flash** = Configuration **1**
- **2 BEEP/2 red LED flash** = Configuration **2**, etc.

This is followed by a **BEEboop, boopboopboop, BEEboop**, at which time, Configuration mode is exited. The SM is now powered off and unpaired. Follow the SM **Pairing** instructions to turn on and re-pair the SM to the device.

**Changing Configuration:** It is not recommended to change the Configuration from the factory setting unless absolutely necessary. Follow the **Checking Configuration** procedure. *After* the audible **Configuration Number BEEP(s)** and *before* the exit Configuration mode **BEEboop** tone, press SW6 the number of times corresponding to the desired configuration. An audible **BEEP(s)/red LED flash(es)** will follow confirming the new Configuration number. This is followed by an audible **BEEboop, boopboopboop, BEEboop**, at which time, Configuration mode is exited. The SM is now powered off and unpaired. Follow the SM **Pairing** instructions to turn on and re-pair the SM to the device.

Check with Stone Mountain to confirm the correct configuration for your **BluSkye®**.

**SM System Reset:** If the SM becomes unresponsive and/or loses audio, you may perform a system reset. Follow the **Checking Configuration** instructions to reset the SM.

**Transmitting Audio (Tx):** If using a PTT application, ensure the SM's PTT button is mapped/connected to the app. To transmit audio, depress SW2 and speak into the microphone opening near the top left side of the SM. Hold the SM about 6 to 8" from your mouth to avoid distortion. Release SW2 when finished transmitting.

**Receiving Audio (Rx):** Incoming audio will automatically be received via the SM speaker. **Note:** Some devices automatically decrease volume by 50% for safety reasons when an accessory is attached. The User may be able to manually adjust the volume control on the device for desired volume level.



**RampClik™ Volume Control:** Receive audio volume is adjusted using SW3. Press the button and hold to increase volume level. Press and immediately release for each step decrease in volume level. An increasingly/decreasingly audible tone plays for each volume level during adjustment. There are 10 available volume levels.

**Emergency/Man Down Alert:** Declare an emergency/man down condition by pressing SW1. Read your device and/or PTT application manual for further information regarding support of this feature.

**Phone Call Control:** Press and release SW5-P once to answer and end an incoming phone call. Press and hold SW5-P for four (4) seconds to reject an incoming call. If the SM is in Secondary mode during an incoming call, toggle back to Primary mode and press SW5-P to answer the call.

**Channel Selection:** Press and release SW4-S and SW5-S to scroll up and down channels, contacts, talks groups, etc. Read your device and/or PTT application manual for further information regarding support and details of this feature.

**3.5mm SureSeal™ accessory jack:** This interface supports remote receive audio accessories, e.g. surveillance kits, etc. The speaker in the SM is disabled when a receive audio accessory is connected to the audio accessory jack. Keep the rubber connector cover inserted when an audio accessory is not attached. Note that only Stone Mountain audio accessories are guaranteed to function correctly with Stone Mountain SM products. Consult your Stone Mountain Product Guide or contact Customer Support for further information.

#### **TruDock™ Remote Charging, Tx & PTT**

**BluSkye®** comes standard with remote cradle charging. Remote Tx and PTT is available as an option. You can purchase **TruDock™** cradles and **HanzFree™** accessories that transform your SM into a 100% hands free charging and communication system. Contact Stone Mountain for more information.

#### **Charging**

1. There is a low battery audible beep that occurs every five (5) minutes when the battery gets to about 10% capacity. The LED will also flash **yellow** in addition to **red** or **blue** (depending on connection status). At this point, the unit should be recharged as soon as possible.
2. To recharge the unit, remove the protective rubber plug from the charging port on the SM cable. Plug the 5.5mm connector of the Stone Mountain approved charger into the cable charging port. The SM LED will flash **green** in addition to **red** or **blue** (depending on connection status) while charging when the SM is powered on. Full charge takes between 5 to 6 hours assuming a completely discharged battery. Replace the protective rubber plug after charging is complete.
3. The SM can also be charged in optional **TruDock™** single bay, vehicle mount and gang chargers.

#### **General Care & Maintenance**

- Do not use solvents, abrasives or other cleaning solutions to clean your Speaker Microphone.
- Clean with mild soap and tap water.
- Do not insert objects into the speaker chamber or the microphone port, as this will adversely impact the audio quality and may result in subsequent water leakage.
- If the SM is connected to a device for 24 hours or more, power cycle the SM to ensure a stable Bluetooth connection.

#### ***Innovation... Quality... Passion***

Designed, Assembled, Tested and Supported with Pride in the USA. At Stone Mountain we strive to provide our customers with innovative products of the highest quality, reliability and value. We welcome and appreciate your input - Feel free to contact us.